

Picture of a face profile

## HTPA80x64d

Infrared Thermopile Array Sensors for Remote Temperature Measurement and Imaging Applications

The HTPA80x64d is the bigger brother of the 32x32d infrared array sensor with a resolution of 80x64 pixel inside a TO8 housing.

Due to the digital SPI interface only 6 pins are needed. It has a built-in EEPROM to store all calibration data and a 16-bit ADC. The speed can be set internally via the sensor clock and ADC-resolution between 20 Hz (highest resolution) and 41 Hz (lower resolution).

### Dimensions - Bottom View

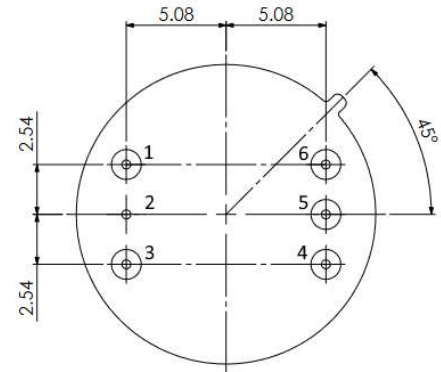

### Available Optics



Optic	L3.9	L4.8	L10	L10.5	L21.5	L33*
FoV [°]	120 x 89	88 x 67	41 x 33	38 x 31	19 x 15	12 x 9
Length of cap [mm]	12.6	14.6	25.7	24.1	35.8	46
Diameter of cap [mm]	20	20	23	23	28	37
F-number	0.8	0.8	0.7	0.95	0.9	1.05

\* Only on request

### Characteristics

Parameter	Value	Tolerance	Unit
Supply voltage (DC)	3.3	+0.3/-0.0	V
Current consumption	27	+8.0/-3.0	mA
Clock frequency (Sensor)	5	± 3	MHz
Ambient temperature range	-20 to 85		°C
Object temperature range	-20 to >1000		°C
Framerate (full frame)	1 to 41		Hz
Framerate (quarter frame)	4 to 164		Hz
NETD (best optics)	155/75**		mK@1 Hz*

\* NETD for required framerate:  $NETD@1Hz \times \sqrt{Framerate}$

\*\* NETD for UHIC Variant

### Pin Configuration (SPI)

Pin	Function
1	EE_Enable
2	VSS
3	VDD
4	SCLK
5	MOSI
6	MISO